

Eclipse Winnox

Burners

Model WX0400

Version 2

Parameter		Specifications	
Blower Type		Packaged Blower	Remote Blower
Maximum Input, BTU/hr (kW)¹	Chamber Pressure "w.c. (mbar)	Nominal (50Hz and 60Hz)	Pressure at Air Inlet 1 psig (70 mbar)
<i>Contact factory for chamber pressures outside the given range, or varying chamber pressure conditions.</i>	-5.0 (-12.5)	4,460,000 (1310)	5,520,000 (1620)
	-3.0 (-7.5)	4,290,000 (1260)	5,280,000 (1550)
	0.0	4,000,000 (1170)	4,900,000 (1430)
	1.0 (2.5)	3,910,000 (1150)	4,760,000 (1400)
	2.0 (5.0)	3,810,000 (1120)	4,620,000 (1350)
Minimum Input, BTU/hr (kW)		340,000 (100)	340,000 (100)
Fuel Inlet Pressure at Ratio Regulator, "w.c. (mbar)²		Maximum	80 (200)
		Minimum	55 (137)
Maximum Chamber Temperature, °F (°C) <i>Tube and plug temperatures should be reduced 150°F when using propane or butane.</i>		Standard combustion tube: 1300 (705) High temperature combustion tube: 1550 (845) Refractory plug: 1800 (985) ³	
Flame Length	Alloy Tube	Flame is inside tube at all times	
Excess Air, % at High Fire		40% - 70%	
Pipe Connections		NPT or BSP connections available	
Flame Detection		Flame rod or UV scanner	
Fuels <i>For any other mixed gas, contact Eclipse Inc.</i>		Natural gas, propane, butane ⁴	
Blower Motor Power, Hp		5.0	-
Weight, lbs (kg)⁵		Alloy Tube	224 (102)
		Refractory Plug	191 (86)
Approvals			

¹ Maximum inputs for packaged blower versions are given for the standard combustion air blower without an inlet air filter.

² For proper performance, this pressure must be kept constant across the burner operating range.

³ See page 3 of this datasheet and Installation Guide 111 for "Refractory Plug Only" installation.

⁴ See Design Guide 111 for more information about typical fuel composition and properties.

⁵ All weights are approximate.

• All inputs are based on gross calorific values and standard conditions: one atmosphere, 70°F (21°C).

• All information is based on laboratory testing. Different chamber size and conditions will affect data.

• Eclipse reserves the right to change the construction and/or configurations of our products at any time without being obliged to adjust earlier supplies accordingly.

Performance Graphs

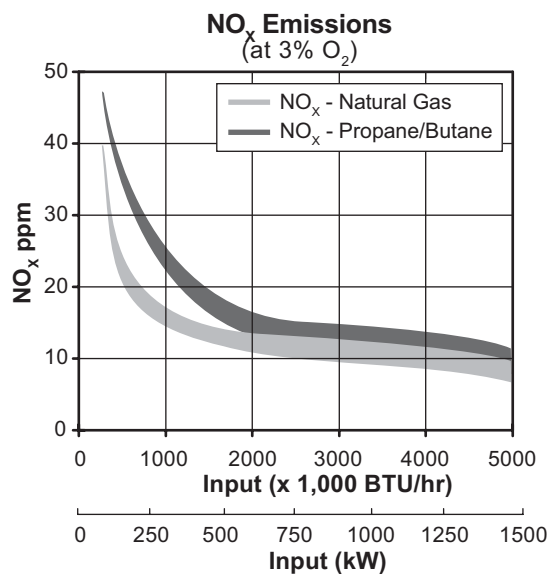
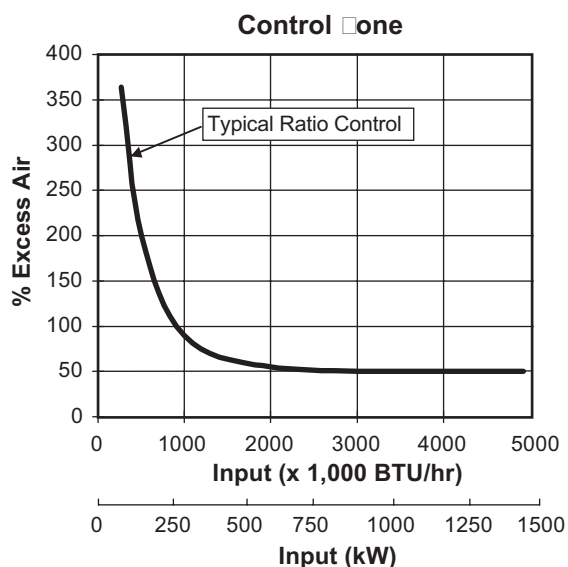

Fuel/Input Measurement

System design must include fuel flow measurement upstream of the burner. Eclipse recommends its 6-5 FOM (Fuel Orifice Meter) assembly number 302086-5 for natural gas. See Bulletin 930 for details.

Secondary By-Pass Fuel Setting:

Fuel	ΔP "w.c. (mbar)*
Natural Gas	8.0 (20.0)
Propane	8.5 (21.6)
Butane	3.5 (8.9)

* Measured between tap "E" and the chamber @ low fire.

NOTE: Input at low fire changes with ratio regulator adjustment.

NO_x emission data is given for:

- Ambient combustion air (~70°F, 20°C)
- Less than 1000°F (540°C) firing chamber
- Minimal process air velocity
- Low fire input adjusted to 340,000 BTU/hr (100 kW)
- Neutral chamber pressure

Emissions are influenced by:

- Chamber conditions
- Fuel type
- Firing rate
- Ratio regulator adjustments
- Combustion air temperature

CO emissions are largely influenced by chamber conditions. Contact your local Eclipse representative for an estimate of CO emissions on your application.

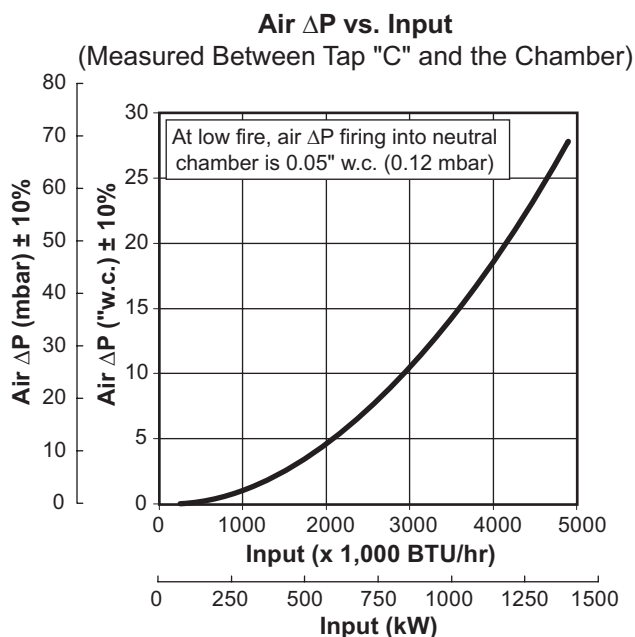

Dimensions in mm (inches)

Packaged Blower

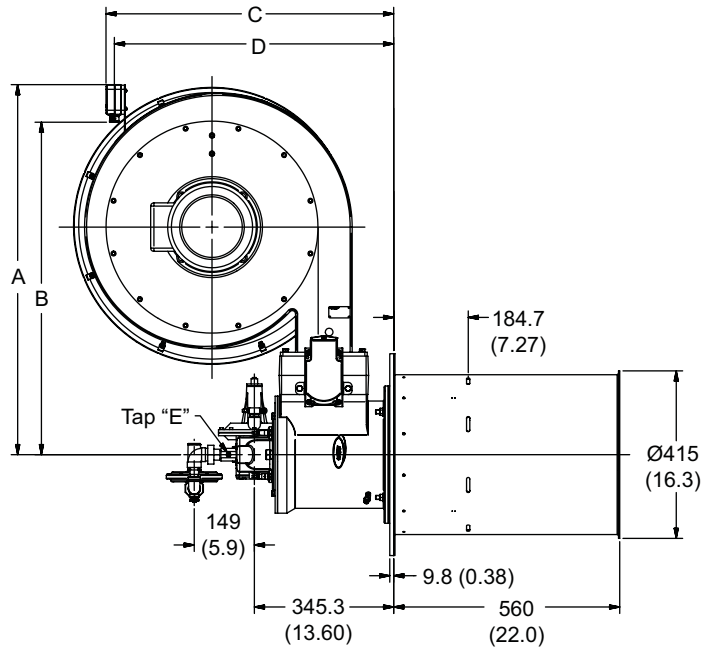
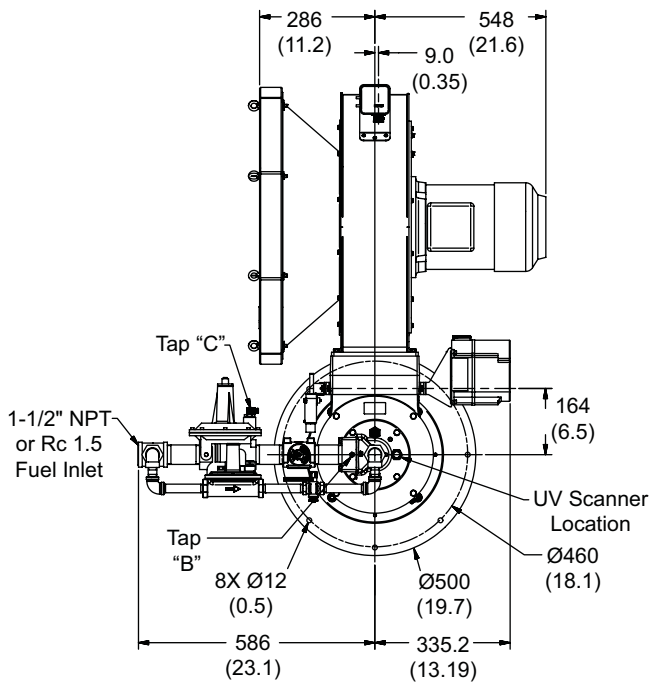

Blower Type		
	60 Hz	50 Hz
Dimensions mm (inches)		
A	853 (33.6)	914 (36.0)
B	760 (30.0)	821 (32.3)
C	627 (24.7)	713 (28.1)
D	647 (25.5)	693 (27.3)

Refractory Plug

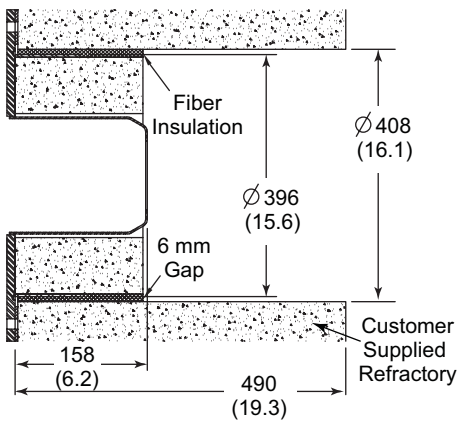

Pilot Ready Option (Shown with remote blower option)

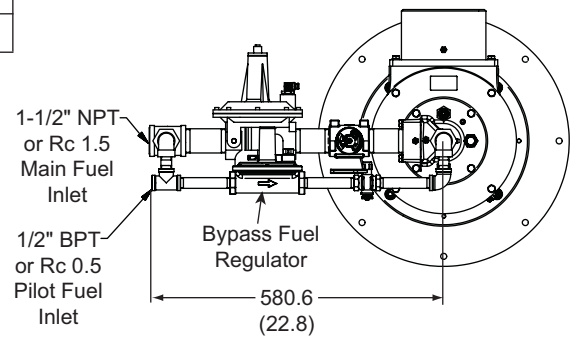

Remote Blower

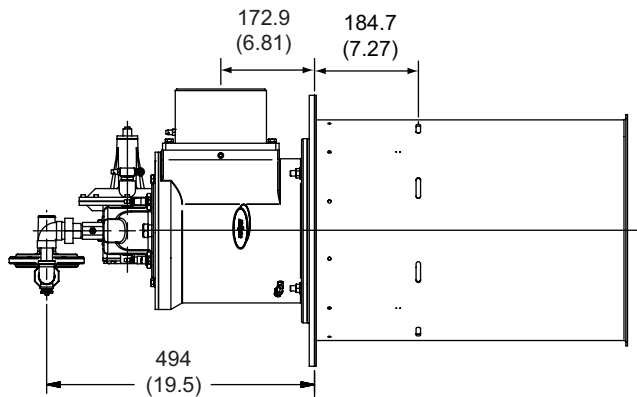
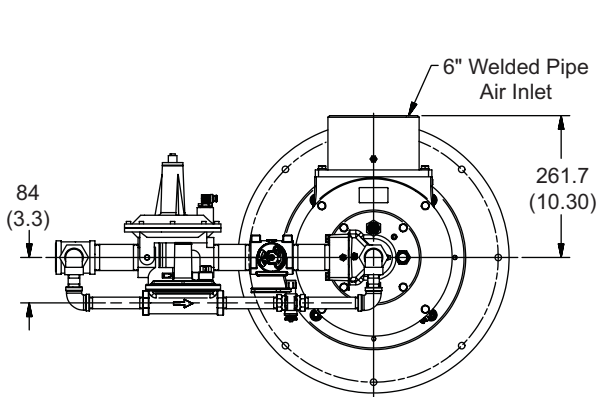



Offered By:

Power Equipment Company
2011 Williamsburg Road
Richmond, Virginia 23231
Phone (804) 236-3800
Fax (804) 236-3882

www.peconet.com